

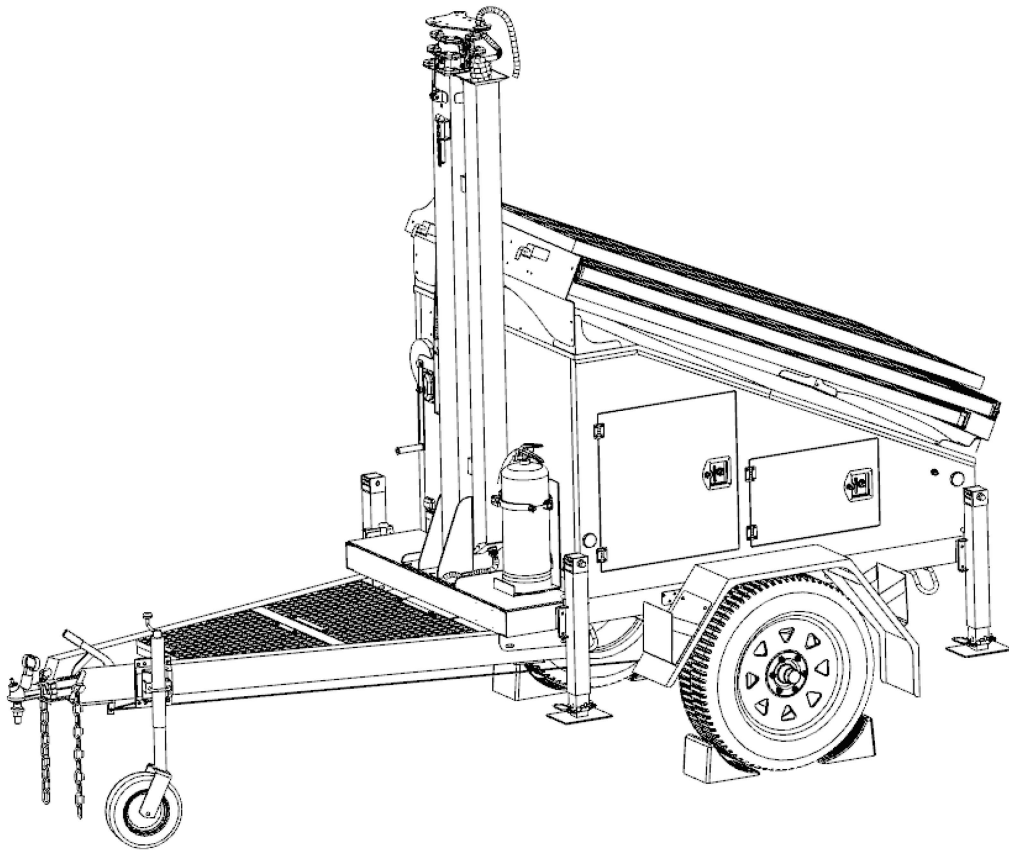

Operating Manual
Solar Trailer



INTRODUCTION

This manual provides information and procedures to safely operate and maintain the solar trailer. For your own safety and protection from physical injury, carefully read, understand, and observe the safety instructions described in this manual. *The information contained in this manual was based on machines in production at the time of publication. 2M Technology reserves the right to change any portion of this information without notice.*

Do not use this equipment for any application other than which it was designed for.

2M Technology recommends that a trained and licensed professional perform all electrical wiring and testing functions.

Keep a copy of this manual with the unit at all times. Additional copies are available from 2M TECHNOLOGY, or can be found at www.2mtechnology.net. Operators manual for MPPT controller, inverter, battery charger and backup generator were also supplied with the unit at the time of shipment from the factory. The manual provides detailed operation and maintenance procedures.

2M TECHNOLOGY
802 Greenview Dr | Grand Prairie TX 75050
USA
Phone +1 866 708 5401
Fax +1 972 999 4113
www.2mtechnology.net

AMIG PARTS TRAINING ASSISTANCE, PROGRAMS
AUTUMN ADAPTATION UNIT

Unit Model Number: _____
Unit Serial Number: _____

	Page
INTRODUCTION	2
TABLE OF CONTENTS	3
SAFETY NOTES	4
OPERATING SAFETY	4
SERVICE SAFETY	5
TOWING SAFETY	6
UNIT SERIAL NUMBER LOCATIONS	6
SAFETY SYMBOL SUMMARY	7
SPECIFICATIONS	8 - 11
SOLAR TRAIER SET UP	12
SOLAR PANELS SLIDING OUT.....	13 - 14
RASING THE TOWER.....	15 - 18
ELECTRICAL OPERATION	19 - 20
MIAN CONTROL PANEL COMPONENTS	21 - 22
SOLAR PANELS RETRACT.....	23 - 24
LOWER THE MAST	25 -28
ELECTRICAL OPERATION	29
TRAILER ASSEMBLY.....	30 - 31
TRAILER CABINET ASSEMBLY.....	32 - 33
TRAILER LIGHTS WIRING (AUSTRALIA)	34
TRAILER LIGHTS WIRING (USA)	35

SAFETY



This is the safety alert symbol. It is used to alert you to potential personal injury hazards. Obey all safety messages that follow this symbol to avoid possible injury or death.

This manual contains DANGERS, WARNINGS, CAUTIONS, NOTICES and NOTES which must be followed to prevent the possibility of improper service, damage to the equipment, personal injury or death. The following formatting options will apply when calling the readers attention to the DANGERS, WARNINGS, CAUTIONS, NOTICES and NOTES.

▲ DANGER

Indicates a hazardous situation which, if not avoided, could result in death or serious injury.

▲ WARNING

Indicates a hazardous situation which, if not avoided, could result in death or serious injury.

▲ CAUTION

Indicates a hazardous situation which, if not avoided, may result in minor or moderate injury.

NOTICE

Indicates a hazardous situation which, if not avoided, may result in property or equipment damage.

Note: Notes contain additional information important to a procedure and will be found within the regular text body of this manual.

OPERATING SAFETY



Before using the solar trailer be sure you read and understand all of the instructions! This equipment was designed for specific applications; DO NOT modify or use this equipment for any application other than which it was designed for. Equipment operated improperly or by untrained personnel can be dangerous! Read the operating instructions and familiarize yourself with the location and proper use of all instruments and controls. Inexperienced operators should receive instruction from someone familiar with the equipment before being allowed to operate or set up the solar trailer. The following points should be practiced at all times:

- The area immediately surrounding the solar trailer should be dry, clean, and free of debris.
- Position and operate the solar trailer on a firm, level surface.
- Do not operate a unit in need of repair.
- Lower tower when not in use, or if high winds or electrical storms are expected in the area.
- Make certain solar trailer is well grounded and securely fastened to a good earthen ground.
- When the mast is raising, make sure area above trailer is open and clear of overhead wires and obstructions.
- Keep area beside trailer clear of people while raising and lowering mast!
- Trailer must be leveled and outriggers extended before raising tower. Outriggers must remain extended while tower is up.
- If for any reason any part of mast hangs up or winch cable develops worn while raising or lowering tower, STOP immediately and replace it.
- Do not remove safety pin or pull mast locking pin while tower is up!
- Do not use tower if insulation on electrical cord is cut or worn through.
- If used in dense crowds, please set up guards 5 meters away from the unit.
- NEVER** take power directly from the batteries.
- If not being used for a long time, please turn off the breaker for the batteries.

- **NEVER** operate electric winch in neutral position when the mast is extending. (Optional electric winch is selected.)
- During mast extending, once the hole for locking pin aligns, stop operating the manual/electric winch.
- During solar charge process, do not unplug each panels and the connectors for solar input on the trailer. It will lead to severe personal injury and equipment damage.
- **NEVER** put conductive metal objects on the batteries.
- Do not forget to insert the safety locking pin when cranking up the outrigger.

Safety



This unit includes solar modules and batteries which are with high voltage circuits capable of causing serious injury or death. Only a qualified electrician should troubleshoot or repair electrical problems occurring in this equipment.

- Before servicing solar trailer, make sure the breakers for solar modules, batteries and load are turned OFF. Disconnect the solar panels and batteries.
- Do not allow water to accumulate around the base of the solar trailer. If water is present, **Do not service!**
- Do not wash the unit with a power washer or high pressure hose.
- Please wear goggles and insulating gloves, using insulation wrench to replace the batteries.
- NEVER** disassemble and repair the mast in uneven place. The mast must be hung and installed with equipment.
- NEVER** replace the tyres and outriggers or adjust and fix the brake system in uneven place.
- NEVER** replace the manual (electric/hydraulic cylinder) winch when the mast is extending.
- Make sure slings, chains, hooks, jacks, and other types of lifting devices are attached securely and have enough weight-bearing capacity to lift or hold the equipment safely. Always remain aware of the position of other people around you when lifting the equipment.

TOWING SAFETY



Towing a trailer requires care! Both the trailer and vehicle must be in good condition and securely fastened to each other to reduce the possibility of an accident. Also, some countries require that trailers be registered and licensed. Contact your local Department of Transportation office to check on license requirements for your particular unit.

- Check that the hitch and coupling on the towing vehicle are rated equal to, or greater than, the trailer's "gross vehicle weight rating" (GVWR).
- Check tires on trailer for tread wear, inflation, and condition.
- Inspect the hitch and coupling for wear or damage. **Do not tow trailer using defective parts!**
- Make sure the trailer hitch and the coupling are compatible. Make sure the coupling is securely fastened to the vehicle.
- Connect safety chains in a crossing pattern under the tongue and if the trailer is with electric brake, attach the breakaway cable **to the tow vehicle's breakaway cable terminal. Do not attach the cable to the trailer hitch.**
- Make sure directional and brake lights on the trailer are connected and working properly.
- Check that all lug nuts holding wheels on are tight and that none are missing.
- Maximum recommended speed for highway towing is 45 m.p.h (72km/h). Recommended off-road towing speed is not to exceed 10 m.p.h. or less depending on terrain.

When towing, maintain extra space between vehicles and avoid soft shoulders, curbs, and sudden lane changes. If you have not pulled a trailer before, practice turning, stopping, and backing up in an area away from heavy traffic.







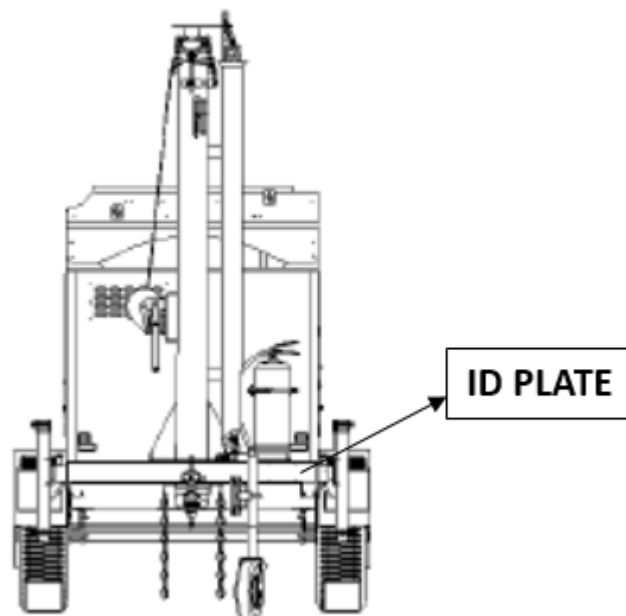

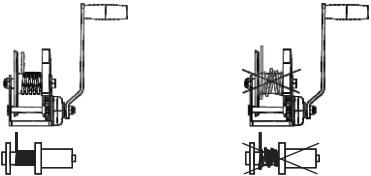
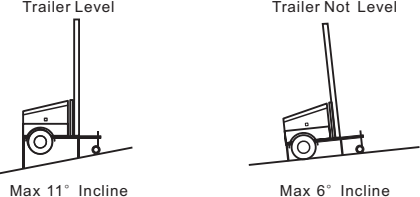

A film of grease on the coupler will extend coupler life and eliminate squeaking. Wipe the coupler clean and apply fresh grease each time the trailer is towed.

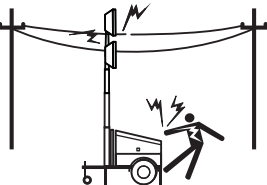
UNIT SERIAL NUMBER IDENTIFICATION

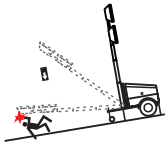
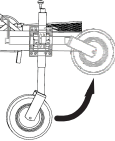
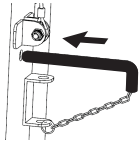
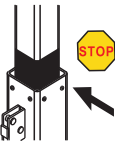
Refer to the locations illustrated below to find the unit ID plate. Important information, such as the unit serial number, GVWR and GAWR for your trailer are found on the plate. Record the information from the plate, so it is available if it is lost or damaged. When ordering parts or requesting technical service information, you may be asked to specify this information.

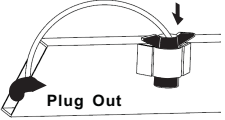

This equipment has been supplied with numerous safety and operating decals. These decals provide important operating instructions and warn of dangers and hazards.

	<p>Always keep tension on steel wires! Slack may cause wire damage and excessive wear!</p>
	<p>Do not exceed trailer installation angles as below.</p>
	<p>Electricity storage devices inside. Contact a qualified electrician for service or to open electrical cabinet. Electric shock will cause serious injury or death.</p>
	<p>Contact with overhead electric wire will cause serious injury or death. Do not place the trailer under electric wire.</p>
 <p>Crush hazard! A falling top device can cause death or serious injury.</p>	 <p>Crush hazard! A falling mast can cause death or serious injury.</p>
 <p>When towing trailer, pull the jockey wheel to horizontal position.</p>	 <p>Fix with pin when mast completely extends.</p>
 <p>Stop operating mast when the warning area appears.</p>	 <p>Pinch point area.</p>
 <p>Anchor/tie down point.</p>	 <p>Forklift here only.</p>
 <p>Place the 7-pin plug to the required position after it comes across the drawbar tube.</p>	 <p>Read and understand the supplied operator's manual before operating unit.</p>

SP□□I□□ATI□□S

M□D□□	2MVSC-3000A	2MVSC-3500A	2MVSC-4000A
□□□□□□□□□□ Detail□			
□□□□□□□□□□	□□2□□□□	2□□2□□□	□□□2□□□
□□□□□□□□□□	□□□□□□□□□	□□□□□□□□□	□□2□□□□□□
□□□□□□□□□□	□□2□□□□□	□□2□□□□□	□□□□□□□□□ □□2□□□□□
Tr□□□□□□□□	□□□□□□□□	□□□□□□□□	□□□□□□□□
□□□□□□□□□□	N□□□□□□□	N□□□□□□□	
□□□□□□□□□□	Mec□□□□□□□□□□	Mec□□□□□□□□□□	Mec□□□□□□□□□□
	Electric□□□□□	Electric□□□□□	Electric□□□□□
Tr□□□□□□□□	□□"	□□"	□□"
□□□□□□□□□□	□□M□□□□□□	□□M□□□□□□	□□M□□□□□□
□□□□□□□	□□□□□□□	□□□□□□□	□□□□□□□
T□□□□□□□	□□□□□□□□□□□□	□□□□□□□□□□□□	□□□□□□□□□□□□
M□□□□□□□□□□ C□□□□□	□□□□□□□□□□	□□□□□□□□□□	□□□□□□□□□□
□□□□□□□□□□	N□□	N□□	N□□ □□□□□□□□□□□□ □□□□□□□□□□□□ □□□□□□□□□□□□
Mat□□□□□□□□□□			
M□□□□□□□□□□ □□□□□□□□□□	M□□□□□□□□□□□□□□□□	M□□□□□□□□□□□□□□□□	M□□□□□□□□□□□□□□□□
□□□□□□	□□□□□□□□□□□□□□□□ □□□□□	□□□□□□□□□□□□□□□□ □□□□□	□□□□□□□□□□□□□□□□ □□□□□
M□□□□□□□□□□	□□□□□□□□□□□□□□	□□□□□□□□□□□□□□	□□□□□□□□□□□□□□
M□□□□□□□□□□□□	O□□□□□□□	O□□□□□□□	O□□□□□□□
C□□□□□□□□	O□□□□□□□	O□□□□□□□	O□□□□□□□
□□□□□□□□□□□□	□□□□□□□	□□□□□□□	□□□□□□□
Tower□□□□□□□□□□			
Le□□□□□	□□□□□□□	□□□□□□□	□□□□□□□
□□□□□	□□□□□□□	□□□□□□□	□□□□□□□
He□□□□□	2□□□□□□	2□□2□□□□	2□□□□□□
□□□□□□□	□□□□□□□	□□□□□□□	□□2□□□□

SPATIATION

M	2MVSC-6000C	2MVSC-6000	2MVSC-6000A
	2	2	2
	2		2
		2	
Tr			
	Mec	Mec	Mec
	Electric	Electric	Electric
Tire	"	"	"
	M	M	M
	r	r	r
T			
M			
C			
			N
M			
M	M	M	M
	L	L	L
M			
M	O	O	O
C	O	O	O
L			
d	2	2	2
H	2	2	2
e			2

SP...ATI...S

M...	2MVSC-7000B	2MVSC-7000C
...
...r ...e	...2...	...2...
...er ...	2 ...	2 ...
...er
Transfer Time	...e	Tr...e ...e
...e ...	Mec...ic...r...e	Mec...ic...r...e
	Electric ...e	Electric ...e
Tire"	..."
...er ...r	...M...	...M...
...	...e	...e
T... H...c r... r...
Mod Guard...ee	...ec...e...	...ec...e...
C...c	... die...e...er...	2... die...e...er...
...c... Ge...er...	... die...e...er...	... die...e...er...
e...e...er...	... die...e...er...
	... die...e...er...	... die...e...er...
	... die...e...er...	... die...e...er...
M...		
M... ...eE...e...	M...ElectricH...c	M...ElectricH...c
...e	...L...e...r...e... ...e	...L...e...r...e... ...e
M...He...
M... ..e...e...	O...	O...
C...C...e	O...	O...
...de...e...d
...r		
Le...
...d	2... ..	2... ..
He...	2... ..	2... ..
...e...	2...

SOLAR TRAILER SET UP

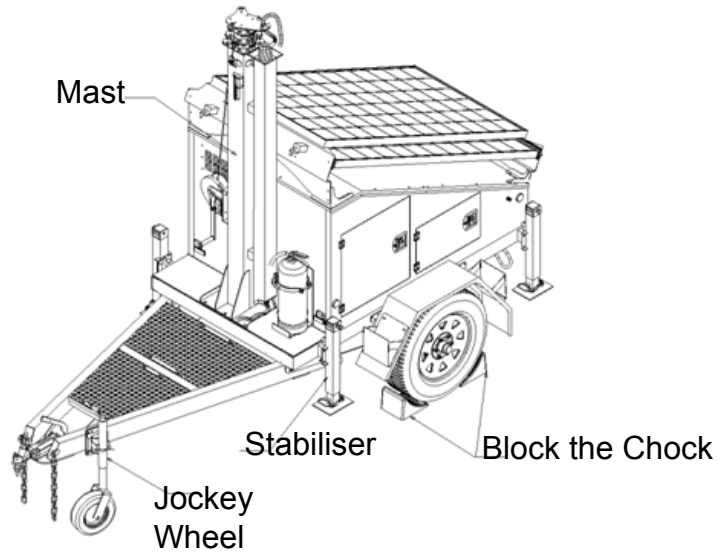

⚠ WARNING

The tower extend to 30 ft (9.14 m). Make sure area above the trailer is open and clear of overhead wire and obstructions.

1. Place the trailer on firm ground that is relatively flat. This will make it easier to level the tower. Apply the hand brake and block the wheels on the trailer to keep it from moving.
2. Connect a good earthen ground to the grounding stud on the base of mast.
3. Pull the locking pin on the jockey wheel and rotate it 90° until the spring loaded pin snaps back into place. Turn the jack handle anticlockwise to raise the trailer drawbar off of the towing vehicle.
4. Pull the locking pins on the outriggers and extend each outrigger until the locking pin snaps back into place (A). Pull out the locking pin in the bottom of the outrigger and fit it to the third hole above (B). Apply the same action for the other 3 outriggers. Turn the jack handle clockwise to start leveling the trailer. Adjust all four jacks by turning their handles clockwise until they are firmly in contact with the ground and the trailer is as level as possible (C). (D is the level meter.)

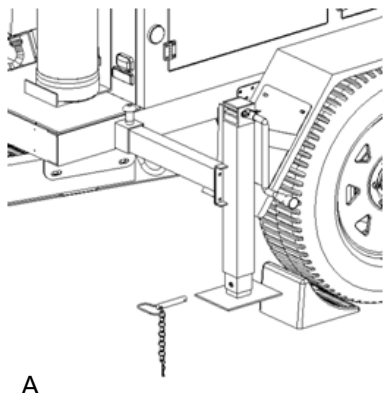

A

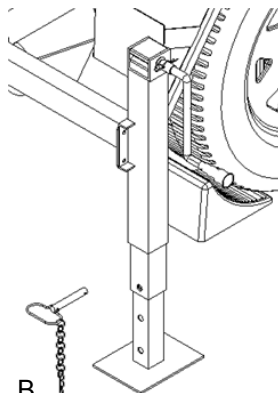

B

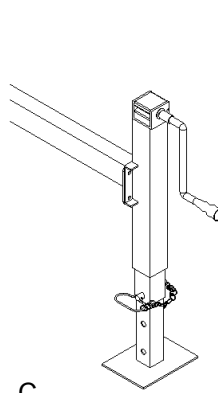

C

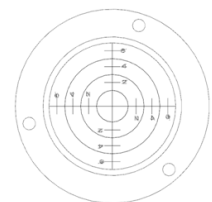

D

SOLAR PANELS SLIDING OUT

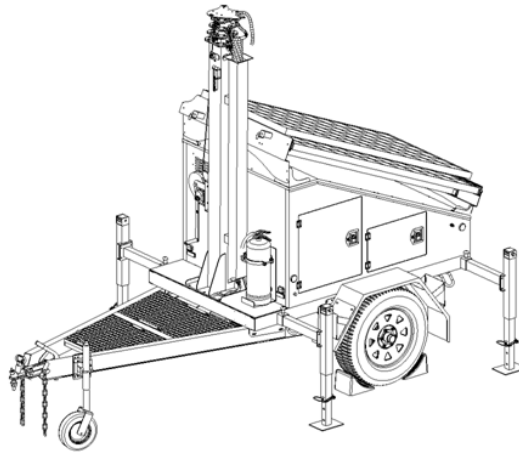

1. Unlock the solar panels (A), press the auto-lock for solar slides (B) and pull the panels to the outermost position and make sure it is locked in place (C).

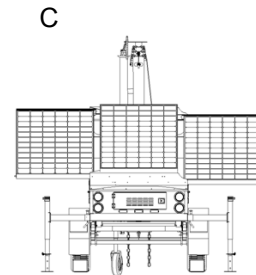
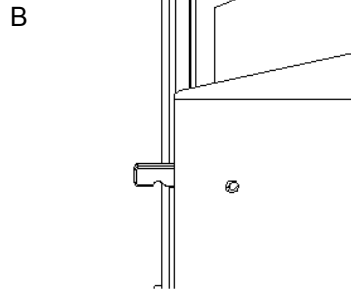
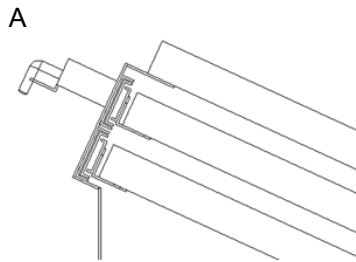

2. Connect the solar panel connectors to those plugs on the cabinet. Turn on the breakers for solar panels and batteries on the control panel.

NOTICE

Under charging condition, make sure the solar panels are faced to the direction of the sun, no shading and the surface is clean.

NOTICE

Do not operate the unit in the dangerous area where there are macadams fly and under weather condition with strong wind. It will damage the solar panels.

⚠ WARNING

Do not unplug the solar panel connectors when it is under charging condition. (It may cause personal injury.)

SOLAR PANELS SLIDING OUT AND ANGLE ADJUSTMENT BY HYDRAULIC SYSTEM

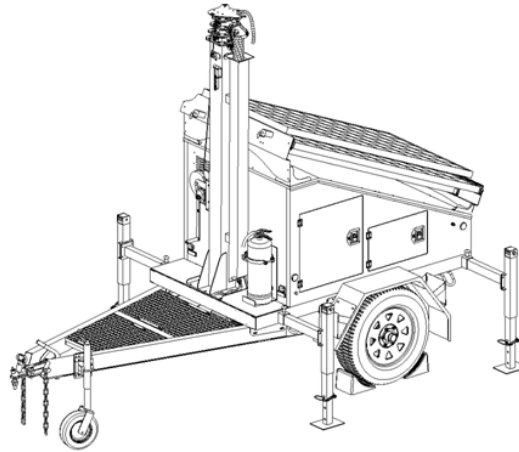

1. Unlock the solar panels (A), press the auto-lock for solar slides (B) and pull the panels to the outermost position and make sure it is locked in place (C).

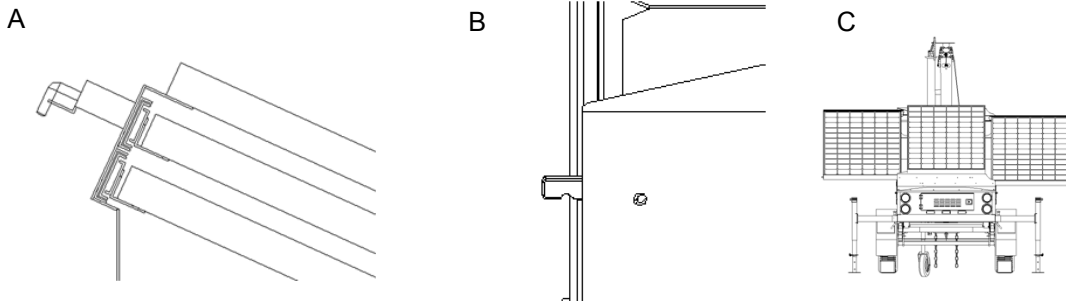

2. Connect the solar panel connectors to those plugs on the cabinet. Turn on the breakers for solar panels and batteries on the control panel.

3. Check oil tank, valve blocks, hydraulic cylinder, hoses and oil joints. Make sure there is no leakage and enough hydraulic oil in the tank. Then press the lifting button on the controller to adjust the solar panels to the required angle.

NOTICE

Under charging condition, make sure the solar panels are faced to the direction of the sun, no shading and the surface is clean.

NOTICE

Do not operate the unit in the dangerous area where there are macadams fly and under weather condition with strong wind. It will damage the solar panels.

⚠ WARNING

Do not unplug the solar panel connectors when it is under charging condition. (It may cause personal injury.)

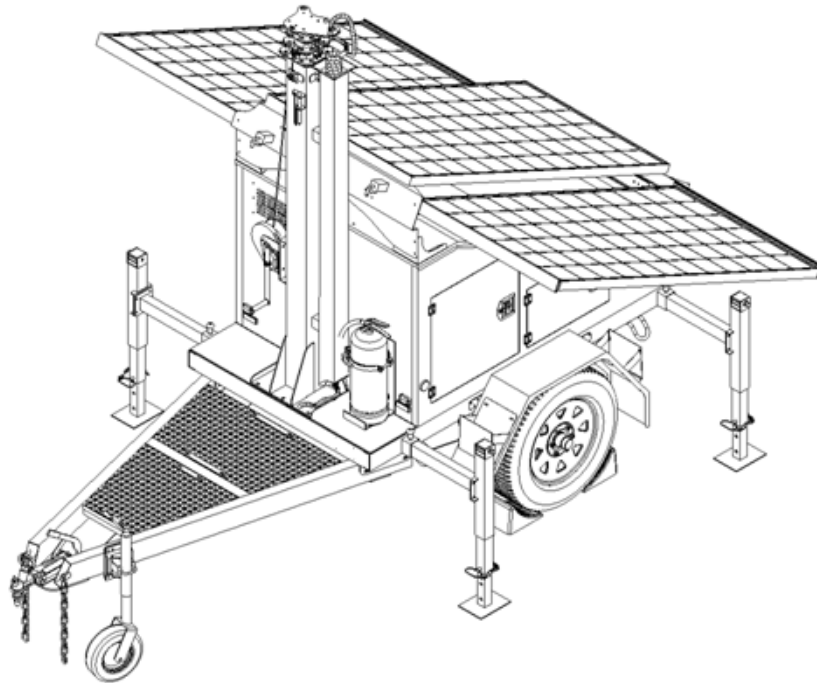

1. Before raising the tower it is necessary to install the top devices and adjust them to the required condition.

▲ WARNING

The trailer must be leveled with the outrigger extended before raising the tower. The outrigger must remain extended while the tower is raised. Failure to level the trailer or extend the outrigger will severely reduce the stability of the unit and could allow the tower to tip and fall.

2. Check mast ropes for excessive wear or damage. Make sure the ropes are properly centered in each pulley. Check the mast electrical cord for damage.

▲ WARNING

Do not operate the unit in the inflation on the electrical cord in contact or worn through. Bare wires in contact with the mast or frame may energize the trailer and cause electrocution or fire or replace cord.

3. Before raising the tower, make sure the steel ropes are orderly and tightened (A). If slack, it will lead to steel ropes wear and even breakage. Crank up the mast clockwise (B) and extend it to the required height. If it is extended to the maximum height, please insert the safety locking pin (C). Extend the mast slowly, making sure that the electrical cord is extending at the top sections of the mast. If, for any reason, the cable begins to develop slack or any of the tower sections get stuck, STOP IMMEDIATELY and contact an authorized service center.

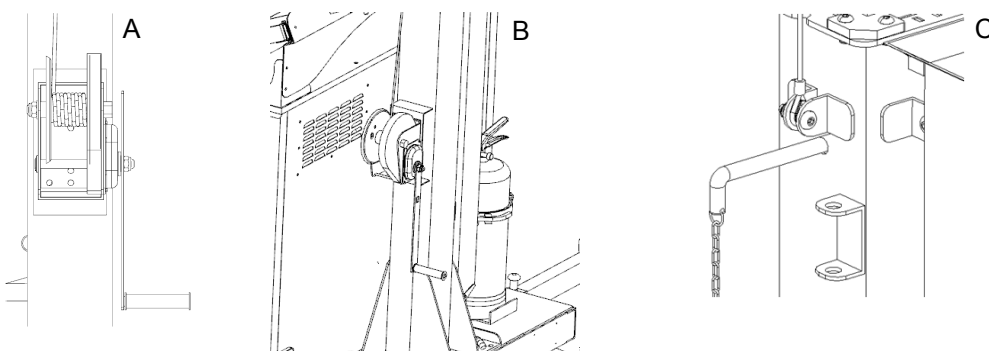

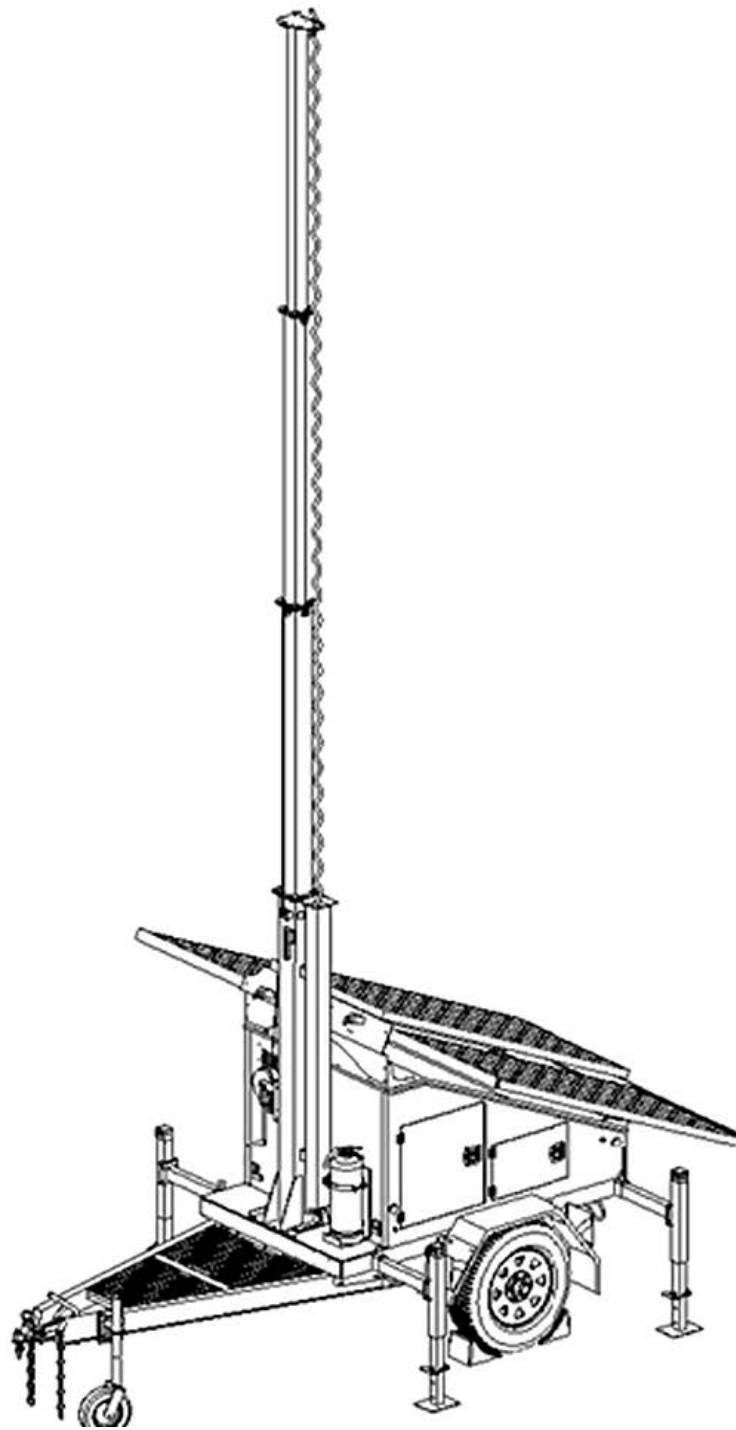

A S **A** **C** **C** **C**

1. Set up and level the solar trailer as described on page 12.
2. Before raising the tower it is necessary to install the top devices and adjust them to the required condition.

▲WARNING

Before raising the tower, make sure the steel ropes are orderly and tightened (A). If slack, it will lead to steel ropes wear and even breakage. Then press the extending button on the controller and lift the mast to the required height. When the mast reaches its maximum height, the limit switch will cut the power off automatically. Please insert the locking pin (B) if, for any reason, the cable begins to develop slack or any of the tower sections get stuck, STOP IMMEDIATELY and contact an authorized service center.

3. Check mast ropes for excessive wear or damage. Make sure the ropes are properly centered in each pulley.
4. Check the mast electrical cord for damage.

▲WARNING

Do not operate the solar trailer beyond the colored mark on top of the lower mast section. If you extend the mast beyond the colored mark, the solar trailer will be damaged and the mast will fall, causing injury or death.

4. Before raising the tower, make sure the steel ropes are orderly and tightened (A). If slack, it will lead to steel ropes wear and even breakage. Then press the extending button on the controller and lift the mast to the required height. When the mast reaches its maximum height, the limit switch will cut the power off automatically. Please insert the locking pin (B) if, for any reason, the cable begins to develop slack or any of the tower sections get stuck, STOP IMMEDIATELY and contact an authorized service center.

CAUTION

Do not extend the mast beyond the colored mark on top of the lower mast section. solar trailers

Extending the mast beyond the colored mark will damage the solar trailer and cause the mast to fall, resulting in injury or death.

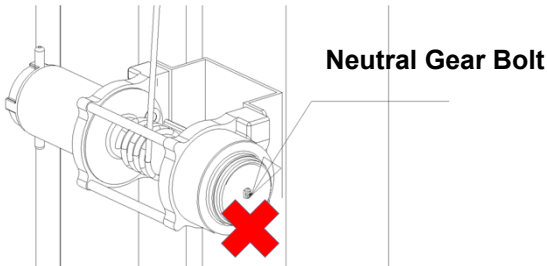
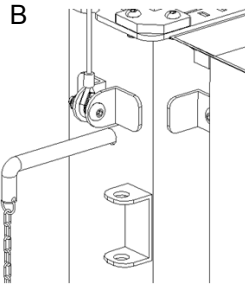
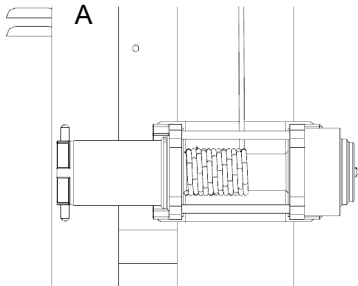

WARNING

When the mast is extended, do not operate the neutral gear bolt on the electric winch. It will lead to sudden falling of the mast and cause equipment damage and personal injury or death.

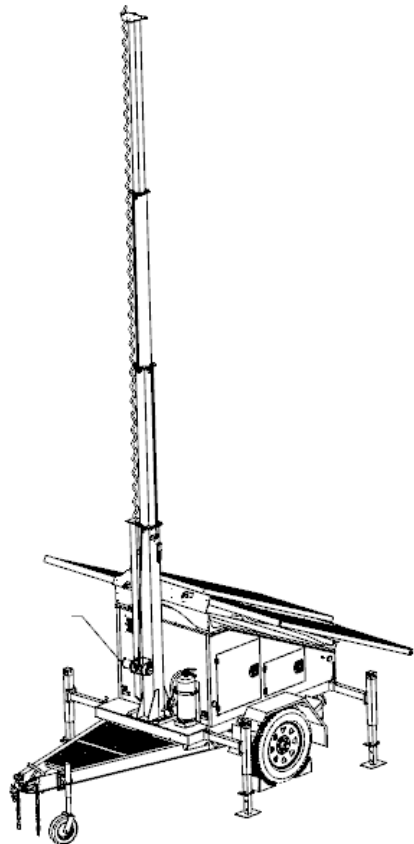

⊠ AISI ⊠ G T ⊠ ⊠ T ⊠ ⊠ ⊠ ⊠ IT ⊠ T ⊠ ⊠ PTI ⊠ ⊠ A ⊠ HYDRAULIC SYSTEM

1. Set up and level the solar trailer as described on page 12.
2. Before raising the tower it is necessary to install the top devices and adjust them to the required condition.

⚠ WARNING

The trailer must be leveled with the outrigger extended before raising the tower. The outrigger must remain extended while the tower is raised. Failure to level the trailer or extend the outrigger will severely reduce the stability of the unit and could allow the tower to tip and fall.

3. Check oil tank, valve blocks, hydraulic cylinder, hoses and oil joints. Make sure there is no leakage and enough hydraulic oil in the tank.
4. Check the mast electrical cord for damage.

⚠ WARNING

Do not operate the unit if the insulation on the electrical cord is cut or worn through. Bare wires in contact with the mast or frame may energize the trailer and cause electrocution. Repair or replace cord.

5. Press the extending button on the controller and lift the mast to the required height. Extend the mast slowly, making sure that the electrical cord is extending at the top sections of the mast. If, for any reason, the cable begins to develop slack or any of the tower sections get stuck, STOP IMMEDIATELY and contact an authorized service center.

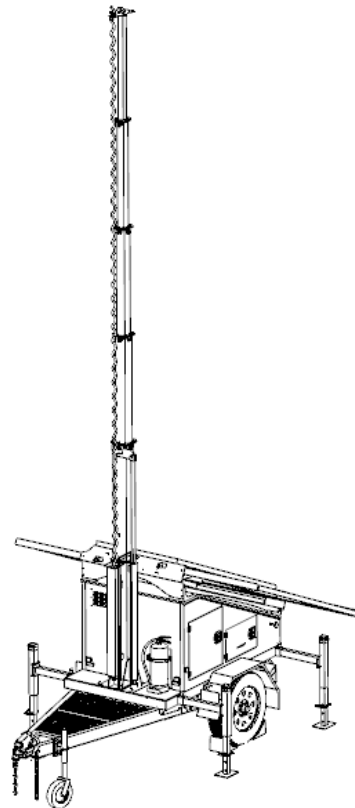

ELECTRICAL OPERATION

1. Please connect the load on the DC/AC output terminal on the solar charge controller.
2. Connect the solar panels with MC4 connectors on the trailer enclosure and turn all the breakers on the control panel to "ON" position.
3. According to the character of the load devices, the user can set the mode **MANUAL/LIGHT-SENSE** on the MPPT controller.
4. Optional inverter: please turn on the breaker for inverter.
5. Optional backup generator set:
 - a. Fill in the oil and fuel. Check if the socket connection on the control panel is secured.
 - b. Turn the key to "ON" position.
 - c. Turn on the circuit breaker inside the generator control cabinet.
 - d. Manually test the auto-start function of genset: change to manual mode and press "START" button to start the generator. Stop it when making sure everything is normal and then change to "AUTO" mode.
6. Backup generator control panel operation:
 - a. Set time
Press "SET" to adjust the time. Input required numbers and press "ENT" for confirmation.



b. Set auto-start and auto-stop voltage

VL represents auto-start voltage while VH represents auto-stop. For a 24V system, the VL is suggested to set in 23V and the VH in 26V.

How to set it:

Press "SET" and the VH blinks. Input numbers "26000" and then press "ENT" for confirmation. The VL blinks. Input numbers "23000" and then press "ENT".

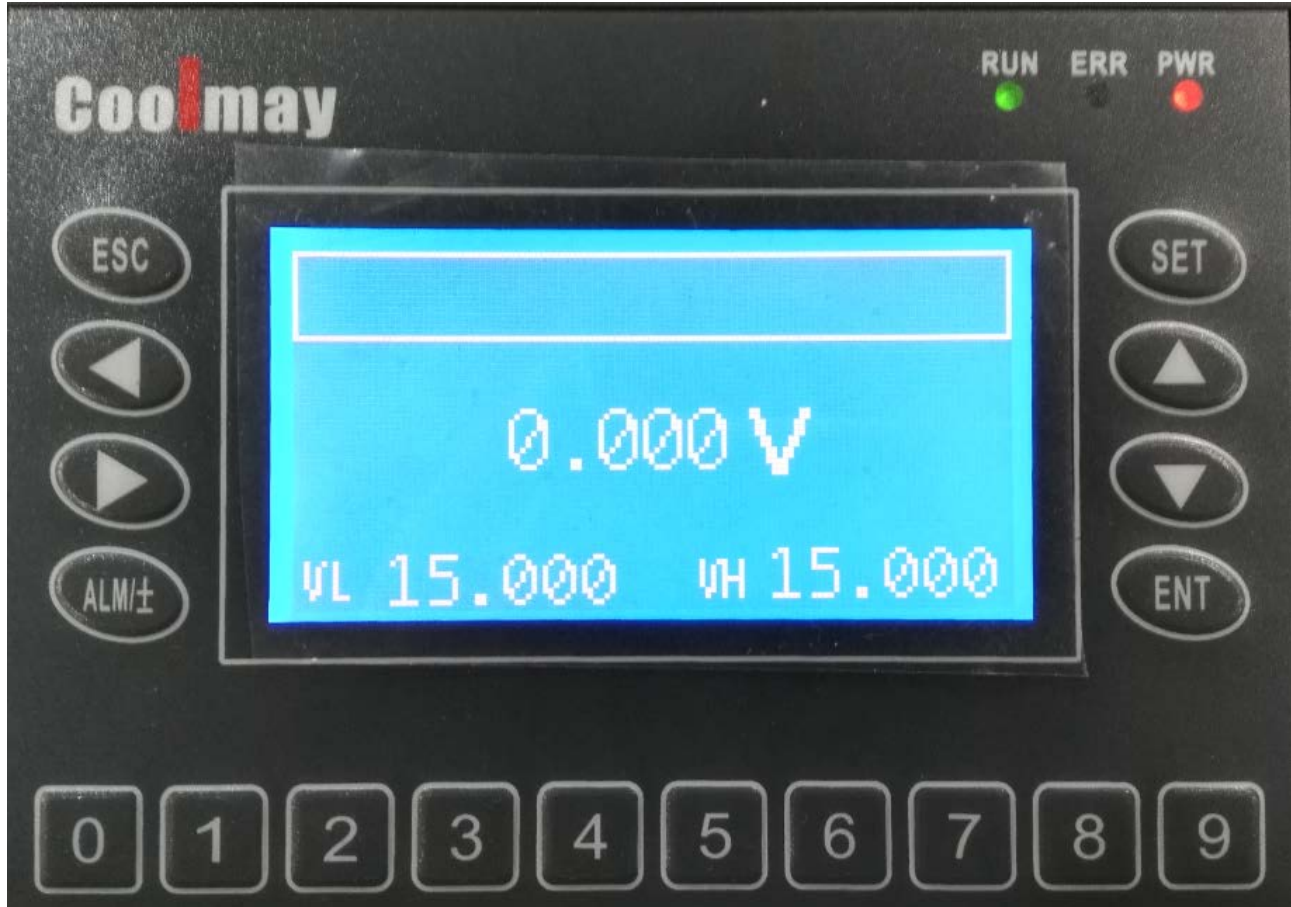

MAINTENANCE PANELS (FOR 4 SOLAR MODULES)

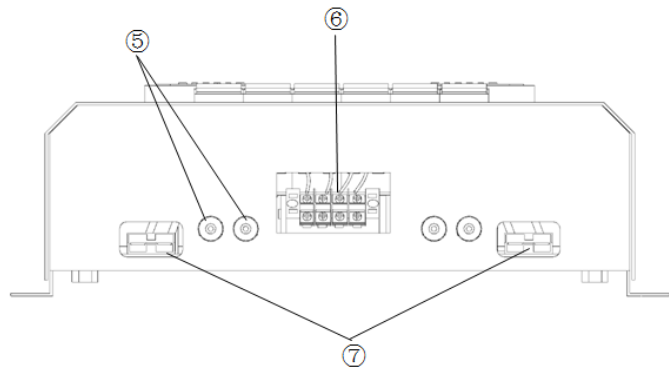
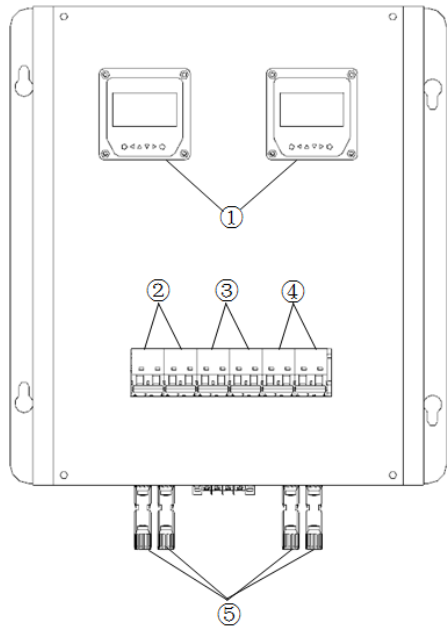

1. **MT50 METER** □ Real-time monitoring of the operational data and working status of a controller, the browse and modification of charge/discharge control parameters and the restoration of factory defaults, based on LCD display and functional key operation.
2. **BREAKERS FOR SOLAR PANELS** □ Turn to "ON" position, the solar panels are in working status.
3. **BREAKERS FOR BATTERIES** □ Protect batteries from short-circuit.
4. **BREAKERS FOR LOAD** □ Turn to "ON" position, the load is in working condition.
5. **SOLAR POWER INPUT** □ The left 2 connectors are for left 2 solar panels, the same for the right 2 connectors.
6. **DC OUTPUT** □ To connect DC devices.
7. **BATTERY CONNECTOR** □ Connect or disconnect the main power.

MAI□ □□□T□□□ PA□□□ □□MP□□□□TS (FOR 3 SOLAR MODULES)

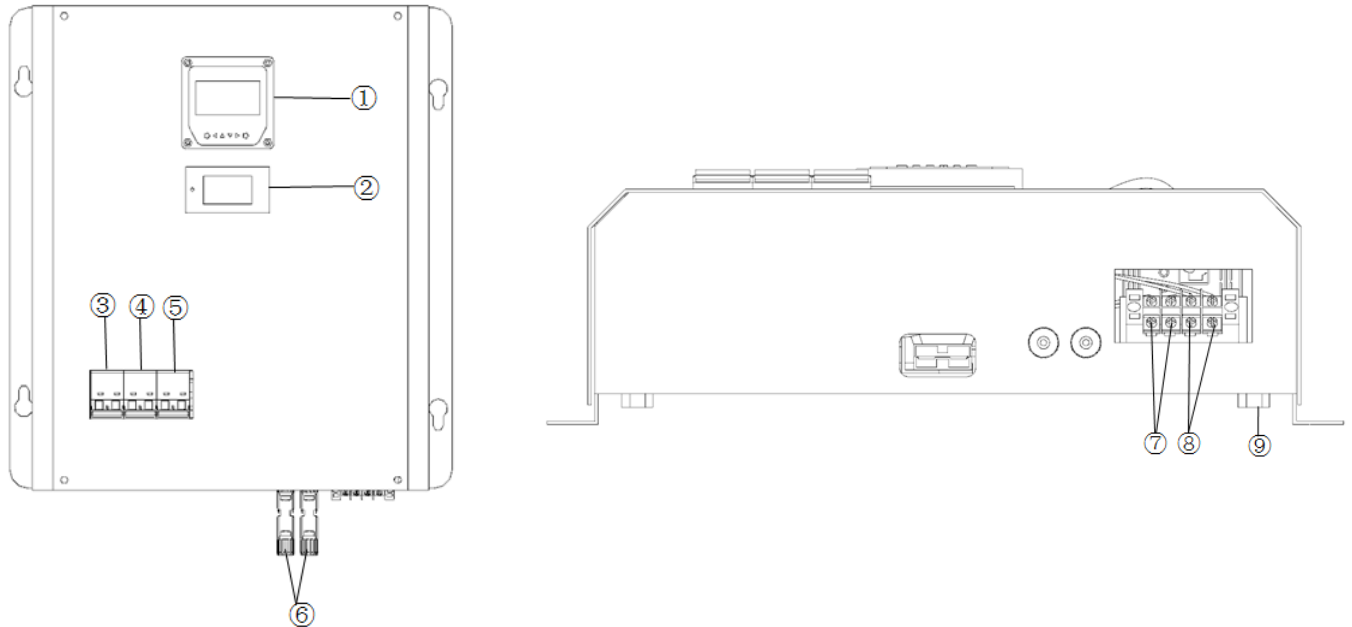

1. **MT50 METER** □ Real-time monitoring of the operational data and working status of a controller, the browse and modification of charge/discharge control parameters and the restoration of factory defaults, based on LCD display and functional key operation.
2. **INVERTER DISPLAY (OPTIONAL):** Show the parameters
3. **BREAKERS FOR SOLAR PANELS** □ Turn to "ON" position, the solar panels are in working status.
4. **BREAKERS FOR BATTERIES** □ Protect batteries from short-circuit.
5. **BREAKERS FOR LOAD** □ Turn to "ON" position, the load is in working condition.
6. **SOLAR POWER INPUT**
7. **DC OUTPUT** □ To connect DC devices.
8. **AC OUTPUT (OPTIONAL):** To connect AC devices.
9. **BATTERY CONNECTOR** □ Connect or disconnect the main power.

SOLAR PANELS RETRACT

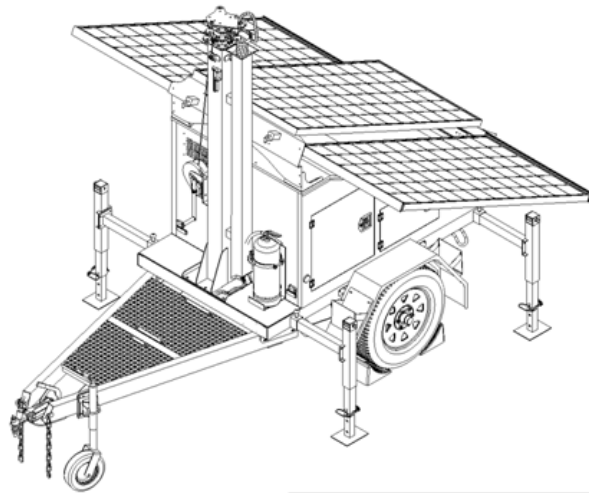

1. Please turn off the breakers for solar panels and batteries. Then disconnect the solar panels with MC4 connectors (B) on the trailer enclosure.

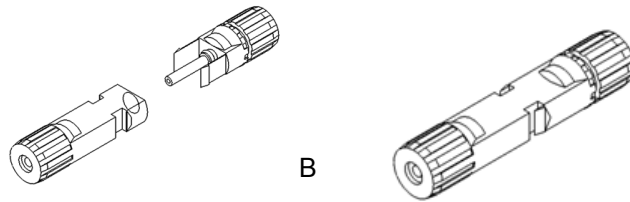
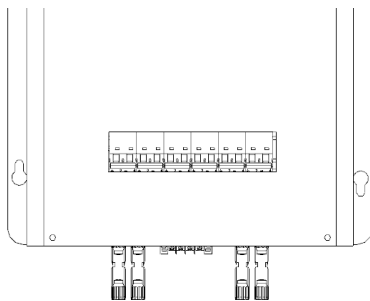

2. Press the auto-lock device (A), retract the solar panel until it is locked in place (B) and fix the panels by spring pin (C).

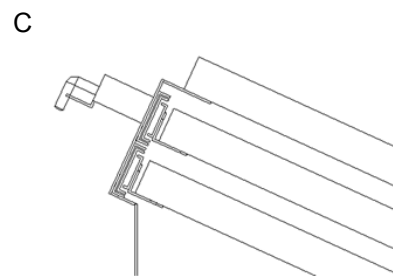
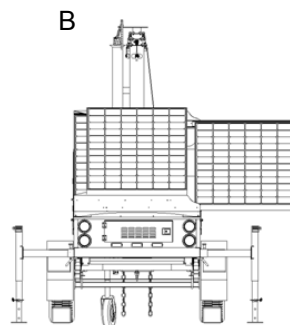
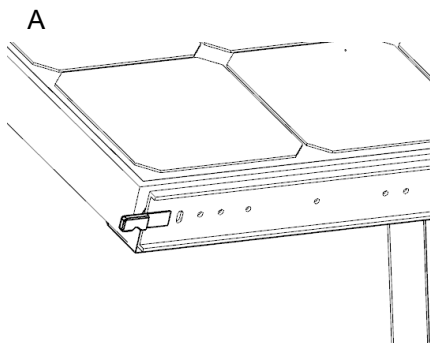

SOLAR PANELS RETRACT AND ANGLE ADJUSTMENT BY HYDRAULIC SYSTEMS

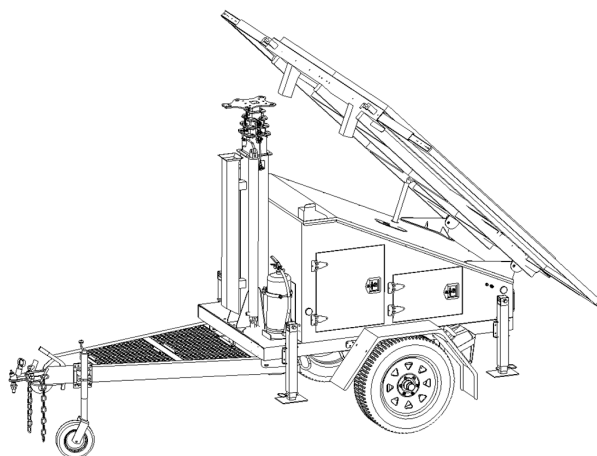

1. Please turn off the breakers for solar panels and batteries. Then disconnect the solar panels with MC4 connectors (B) on the trailer enclosure.

⚠ WARNING

Do not unplug the solar panel connectors when it is under charging condition. (It may cause personal injury.)

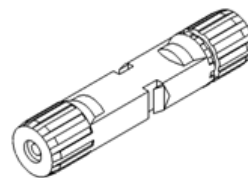
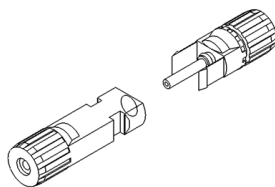
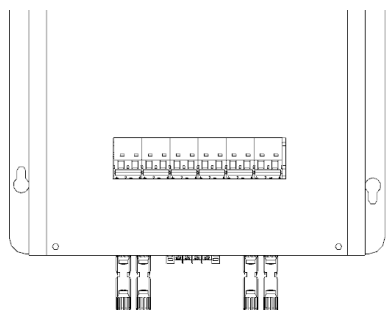

2. Press the lowering button the controller until the solar panels are adjusted to their original position.
3. Press the auto-lock device (A), retract the solar panel until it is locked in place (B) and fix the panels by spring pin (C).

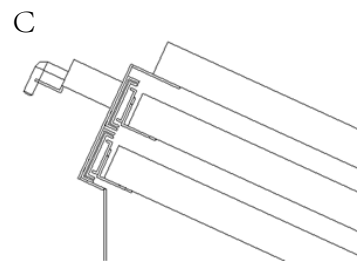
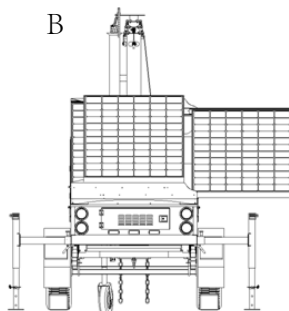
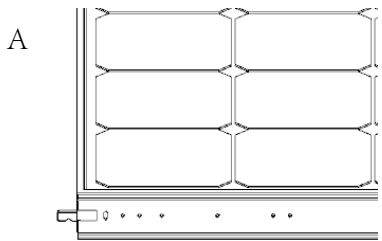

LOWER THE MAST

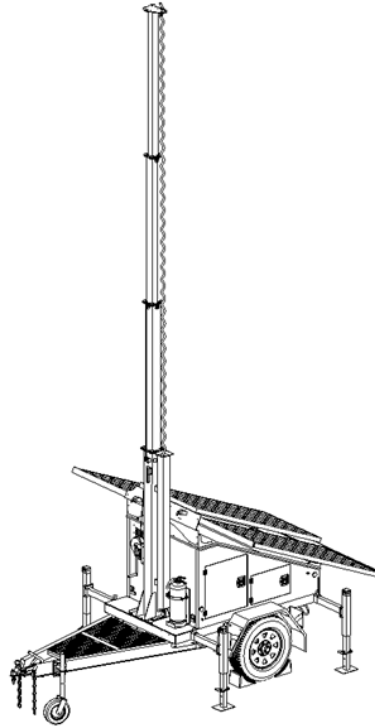

1. Check the rope is correctly secured in the Mast. The rope is correctly secured in the electric winch.
2. Check the electric cord is disconnected.

⚠ WARNING

Do not operate the unit unless the mast is fully extended. Do not operate the unit unless the mast is fully extended. Do not operate the unit unless the mast is fully extended.

3. Pull the locking pin out (A), crank the manual winch in anti-clockwise direction (B), lower the mast to its original static height and make sure the steel rope is orderly (C).

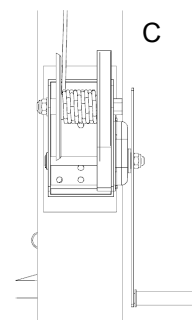
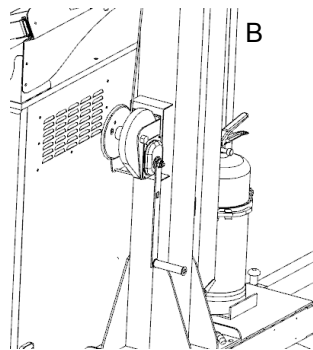
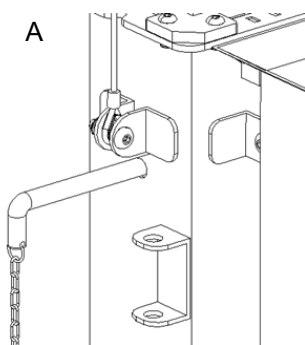

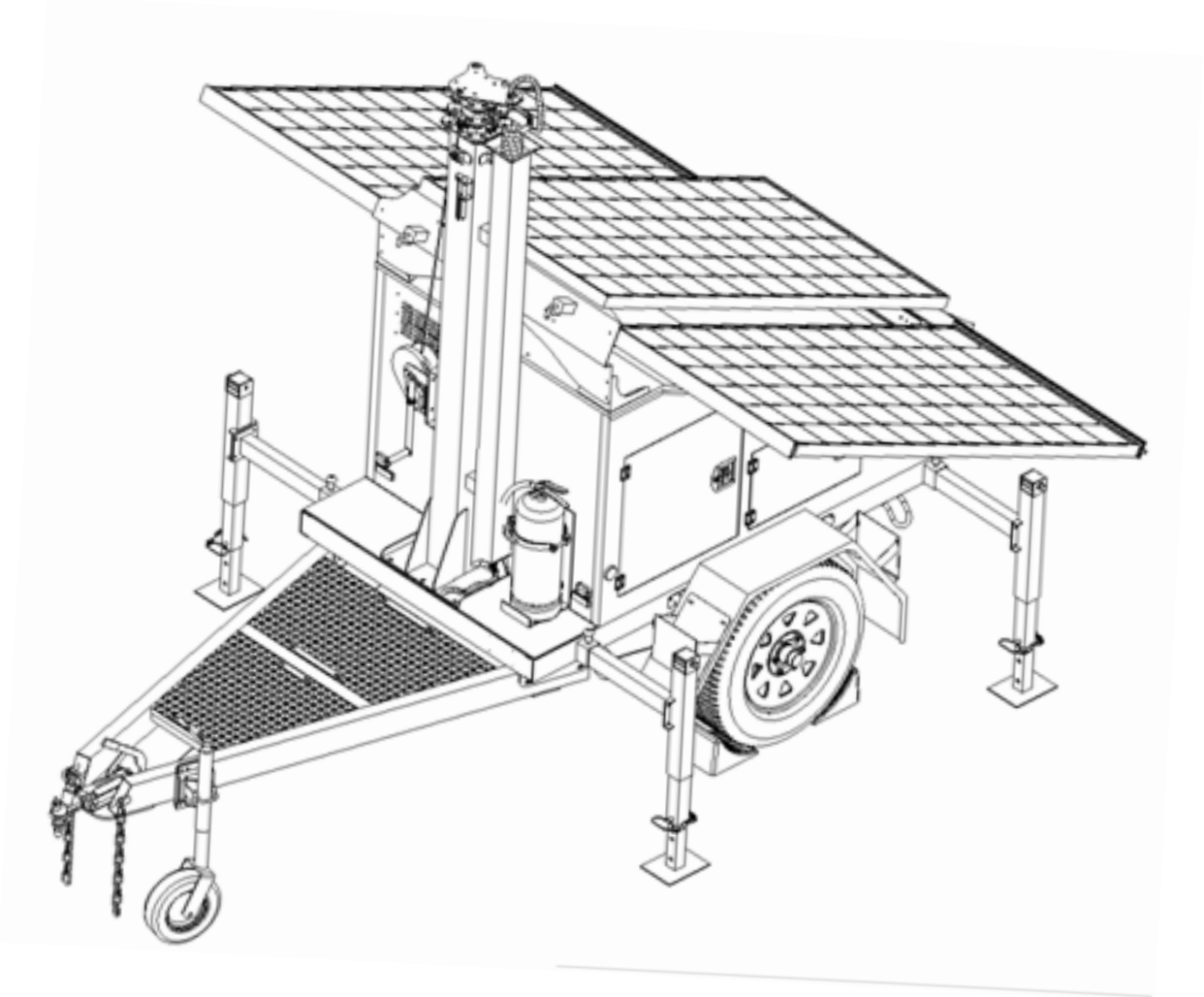

LOWER MAST

1. Check the rope is centered in the drum. Make sure the rope is properly centered in the drum.
2. Check the electric cord is dry.

⚠ WARNING
 Do not operate the unit if the rope is not properly centered in the drum. **Brake** the drum if the rope is not properly centered in the drum.

3. Pull the locking pin out (A), press the lower button on the electric winch controller, lower the mast to its original static height and make sure the steel rope is orderly (B).

⚠ CAUTION
 The solar trailer disconnect will disconnect power to the electric winch to prevent it from overextending.

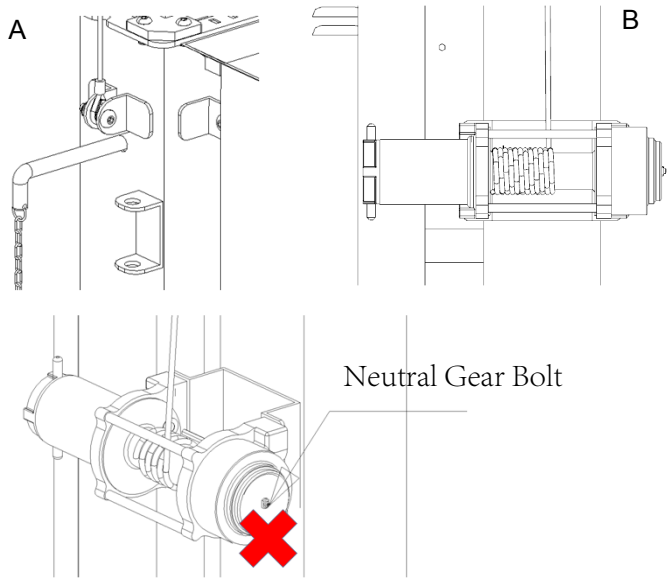

WARNING
 When the mast is extended, do not operate the neutral gear bolt on the electric winch. It will lead to sudden falling of the mast and cause equipment damage and personal injury or death.

LOWER MAST HYDRAULIC

1. Check oil tank, valve blocks, hydraulic cylinder, hoses and oil joints. Make sure there is no leakage and enough hydraulic oil in the tank.
2. Check the electric cord and its condition.

⚠WARNING

Do not operate the unit until the hydraulic cord is repaired or replaced. Repair or replace cord.

3. Press the lower button on the hydraulic system controller and lower the mast to its original static height.

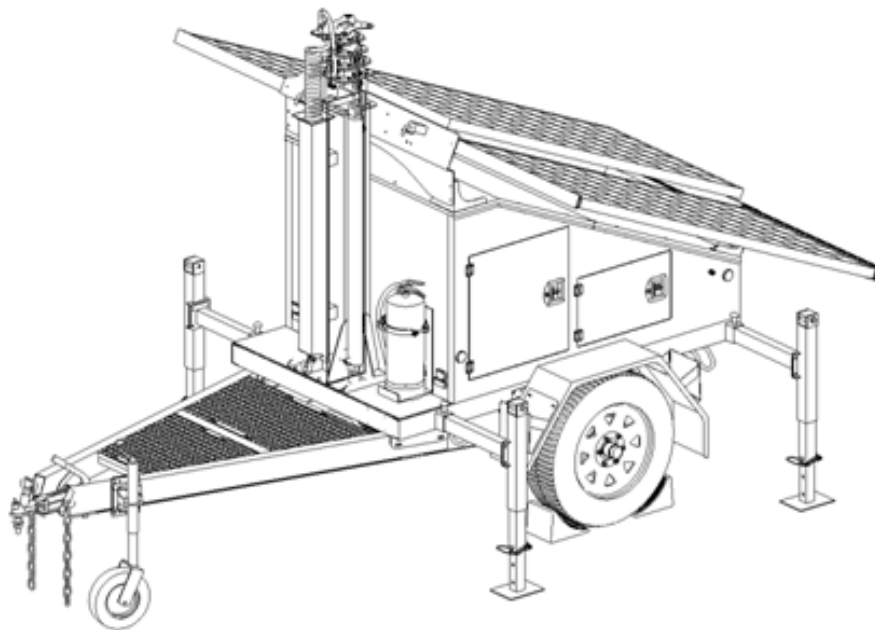

ELECTRICAL OPERATION

1. Turn off the breaker for battery and load on the control panel.
2. Optional inverter: please turn off the breaker for inverter
3. Optional backup generator:
 - a. Please turn the key on control panel to "OFF" position.
 - b. Turn off the breaker inside the control cabinet for generator.

TRAILER CHASSIS ASSEMBLY

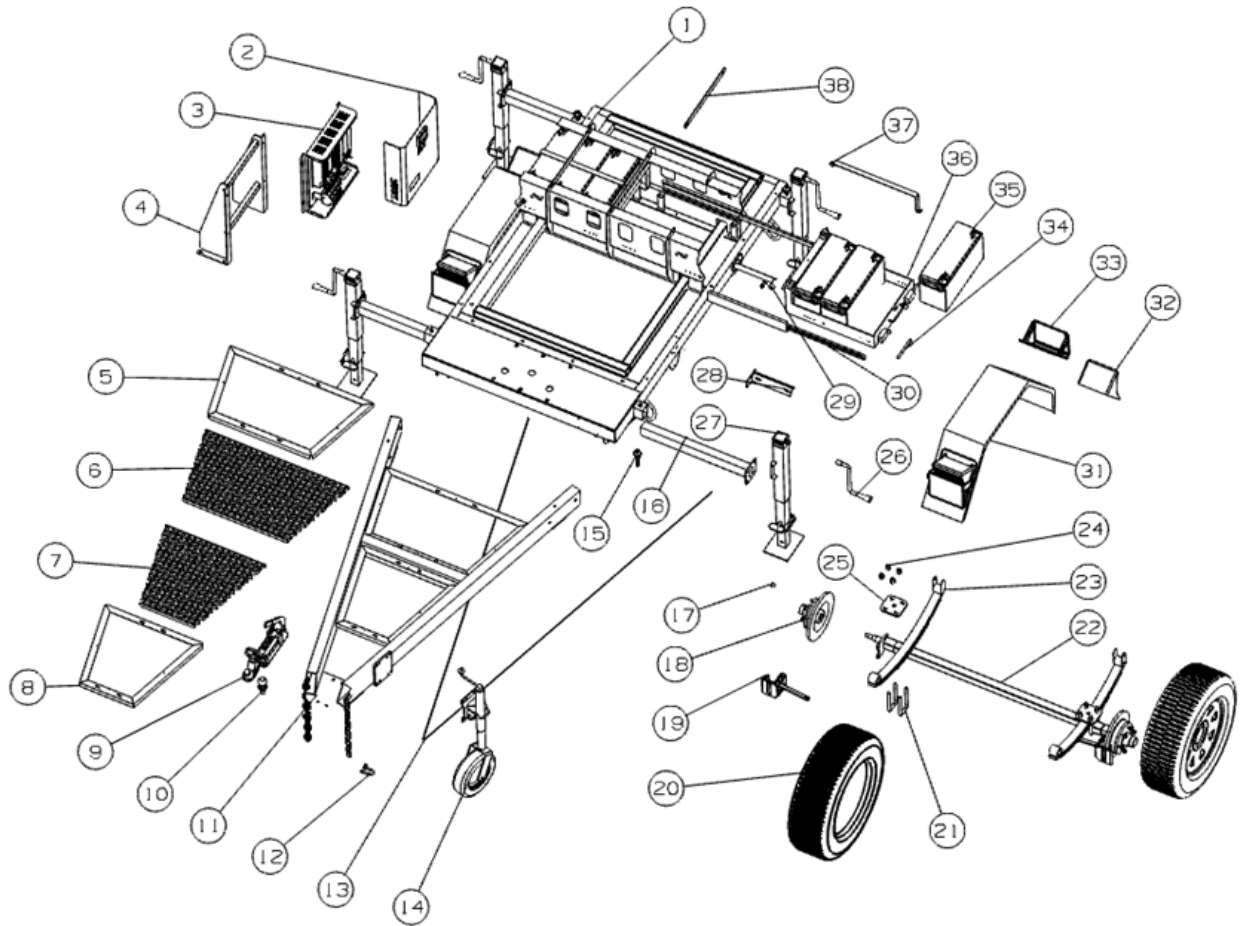

Item No	Qty	Description
1	1	Chassis
2	1	Control cabinet front mounting panel
3	1	Control cabinet rear mounting panel
4	1	Control cabinet bracket
5	1	Fixture for grating plate
6	1	Grating plate
7	1	Grating plate
8	1	Fixture for grating plate
9	1	Ball hitch
10	1	50mm ball
11	2	Safety chains
12	1	Connector for safety chains

13	1	Brake cable
14	1	Jockey wheel
15	4	Lock pin for stabiliser
16	4	Side tube for stabiliser
17	10	Nut lug
18	2	Brake disc
19	2	Mechanical brake caliper
20	2	Tyre
21	4	U-bolt
22	1	Wheel axle
23	2	Spring plate
24	8	Nuts for U-bolt
25	2	Plate
26	4	Stabiliser handles
27	4	Stabiliser
28	2	Fender mounting bracket (front)
29	2	Fender mounting bracket (rear)
30	4	Battery drawer slide
31	2	Fender
32	4	Wheel chock
33	4	Wheel chock bracket
34	4	Battery drawer locking pin
35	4/6/8	Battery
36	2	Battery drawer
37	2	Battery fixture
38	3	Reinforcing plate for battery drawer

TRAILER CABINET ASSEMBLY

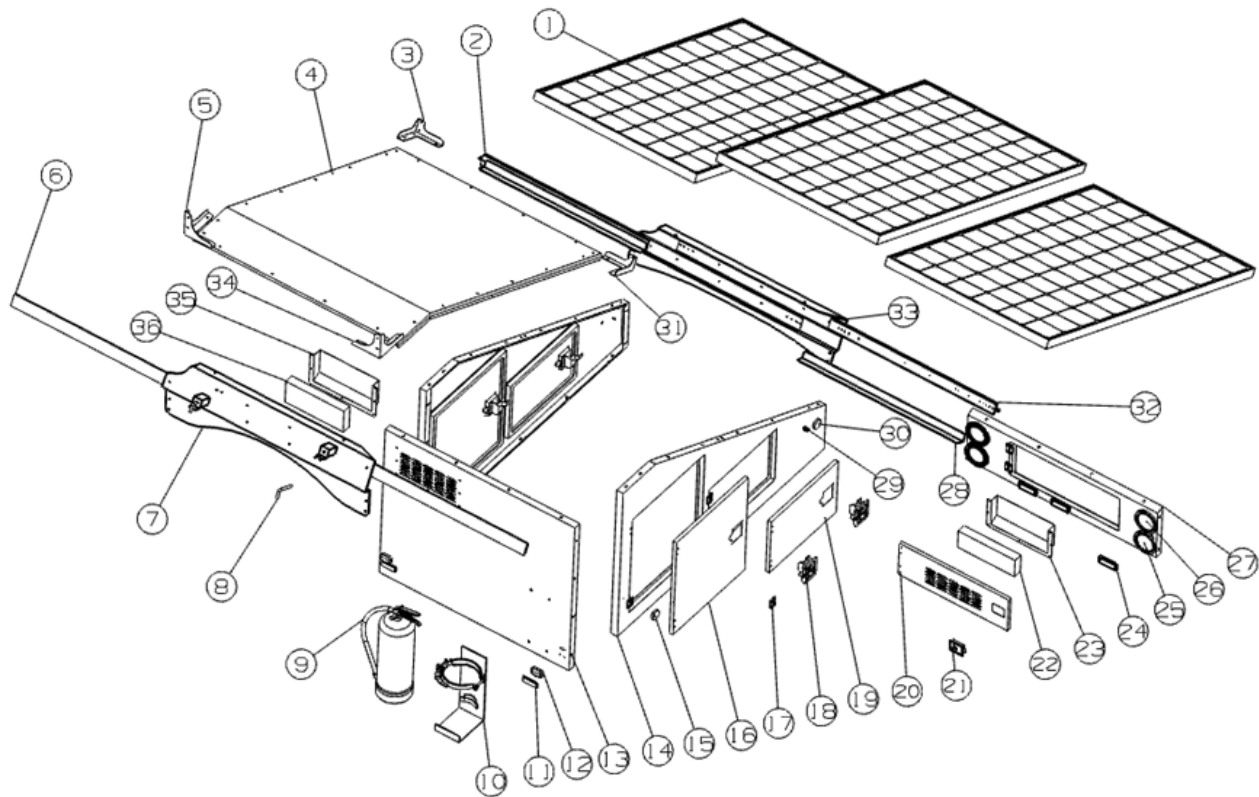

Item No.	Qty	Description
1	3/4/8	Solar panel
2	1	Solar slide with auto-lock (left)
3	1	Rear mounting bracket
4	1	Cover for trailer enclosure
5	1	Front mounting bracket
6	2	Solar panel mounting bracket
7	1	Mounting bracket for solar slides
8	2	Locking pin for solar panel
9	1	Fire extinguisher
10	1	Fire extinguisher bracket
11	2	Reflector

12	2	Front marker light
13	1	Front plate for trailer enclosure
14	2	Side plate for trailer enclosure
15	2	Side reflector
16	2	Door
17	10	Door hinge
18	4	Door lock
19	2	Door
20	1	Rear door
21	1	Rear door lock
22	1	Rear ventilation filter
23	1	Rear ventilation filter holder
24	3	Rear marker light
25	2	Brake light
26	2	Turn signal
27	1	Rear plate for trailer enclosure
28	2	Solar panel mounting bracket
29	3/4	MC4 connector
30	2	Side reflector
31	1	Rear mounting bracket
32	1	Solar slide with auto-lock (right)
33	1	Mounting bracket for solar slides
34	1	Front mounting bracket
35	1	Front ventilation filter holder
36	1	Front ventilation filter

TRAILER LIGHTS WIRING (AUSTRALIA)

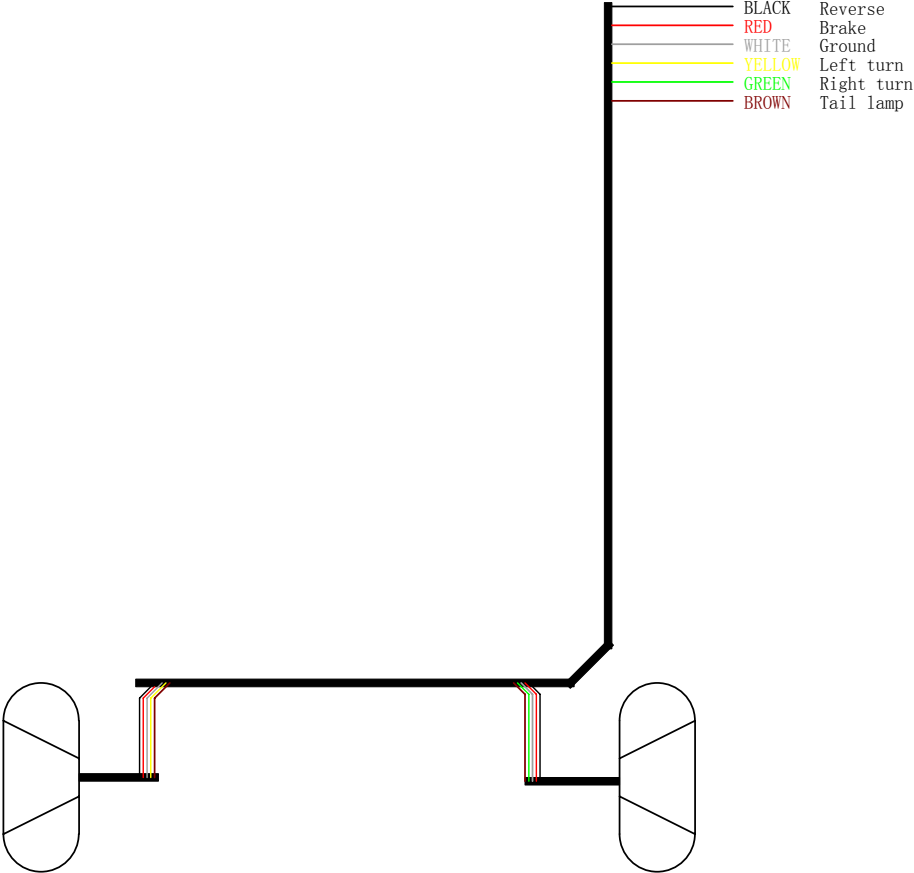

TRAILER LIGHTS WIRING (USA)

